



Terry *Lifestyle*[®]

THL 600
Domestic Lift

The flexible and versatile choice for easy access

The THL 600 Domestic Lift is a versatile solution for travelling between the floors in your home safely and easily. With a variety of sizes and configurations available, you are sure to find a model that suits your requirements perfectly. The spacious THL 600 can accommodate up to six people and it also provides wheelchair access. A range of options allow you to customise the lift to suit your home décor.

Features

- Different sizes and options available to suit your needs
- Quick installation with minimal building works required
- Option for a half-height door on the top floor
- Patented screw/nut technology
- Low maintenance and operating costs
- Battery-powered emergency lowering
- Made with 95% recyclable materials
- 'A' rated energy consumption according to VDI4707
- Compliant with European Machinery Directive 2006/42/EC and European standard EN 81-41

Standard specification

- Application range: People with impaired mobility and wheelchair users. Internal locations.
- Safe working load: 500 kg
- Maximum travel: 13 m (13,000 mm)
- Maximum number of stops: 6
- Pit depth: 50 mm (no pit is required when there is a threshold)
- Rated speed: 0.15 m/s
- Power supply electrical requirements:
1-phase 240 V 50 Hz/9 A/16 A slow
3-phase 240 V 50 Hz/9 A/16 A slow
- Emergency lowering: Battery-powered

Sizes and dimensions (in mm)

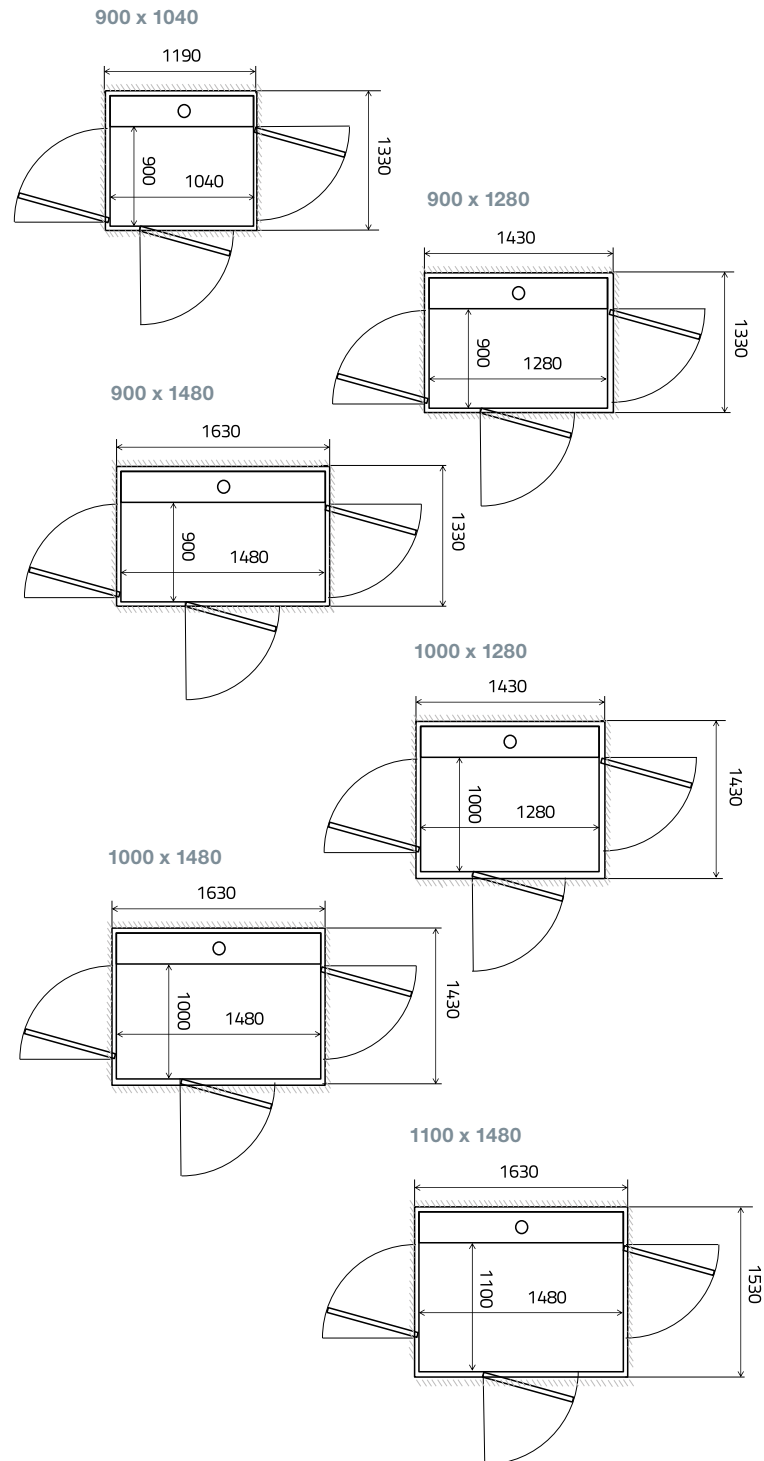

Call us today on: **0345 365 5366**
or e-mail: sales@terrylifts.co.uk



Terry
total lift solutions

Terry Group Ltd. Longridge Trading Estate, Knutsford, Cheshire, WA16 8PR
tel (outside UK): 00 44 (0)1565 650376
www.terrylifts.co.uk

